



USER MANUAL

# **Elo PayPoint Dock**

SW602291 Rev A



# Table of Contents

- Chapter 1: Product Overview ..... 3**
- Product Description ..... 3
- Payment Features ..... 3
- Chapter 2: Apple® iPad Dock Operation ..... 4**
- Elo PayPoint iPad® Dock Register Layout ..... 4
- Chapter 3: Technical Support ..... 11**
- Chapter 4: Safety & Maintenance ..... 13**
- Chapter 5: Regulatory Information ..... 18**
- Chapter 6: Warranty Information ..... 21**
- Getting in Touch with Us ..... 22

# Chapter 1: Product Overview

## Product Description

---

Elo PayPoint iPad® Dock is an all-in-one cash register designed to run with an iPad. The system is integrated with Receipt Printer, Magnetic Stripe Reader, Barcode Reader, Cash Drawer, and Customer Facing Display. In addition to built-in peripherals, the system has a serial port to support external devices.

## Payment Features

---

The Elo PayPoint iPad Dock application supports cash, checks, and card payment transactions.

# Chapter 2: Apple® iPad Dock Operation

## Elo PayPoint iPad® Dock Register Layout

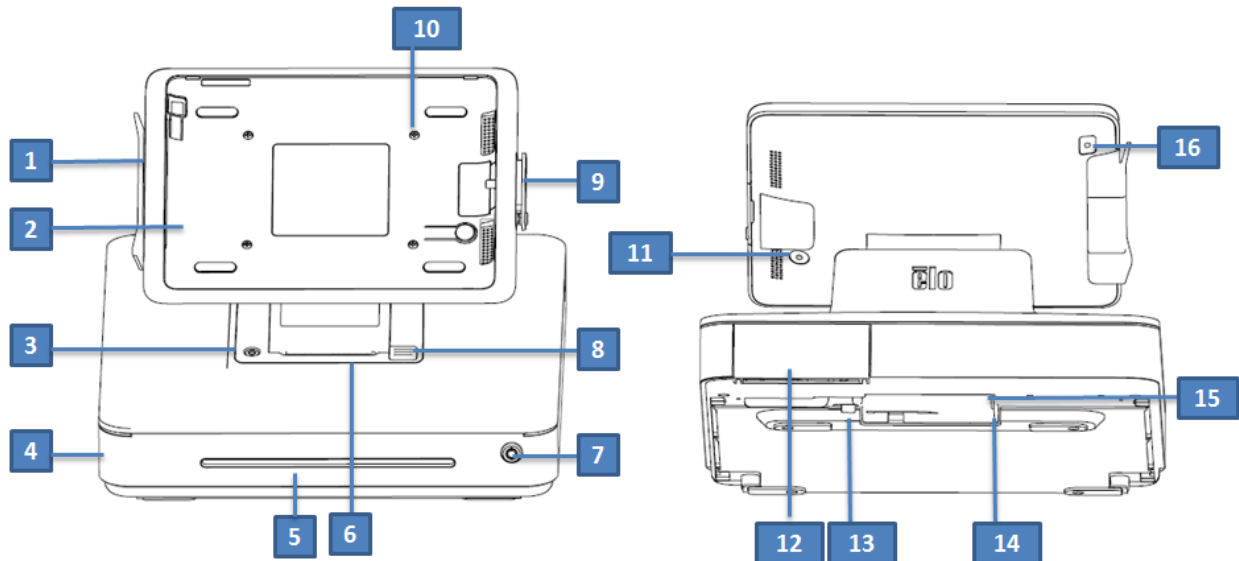

Figure 1. Elo PayPoint iPad® Dock front view (left) and back view (right)

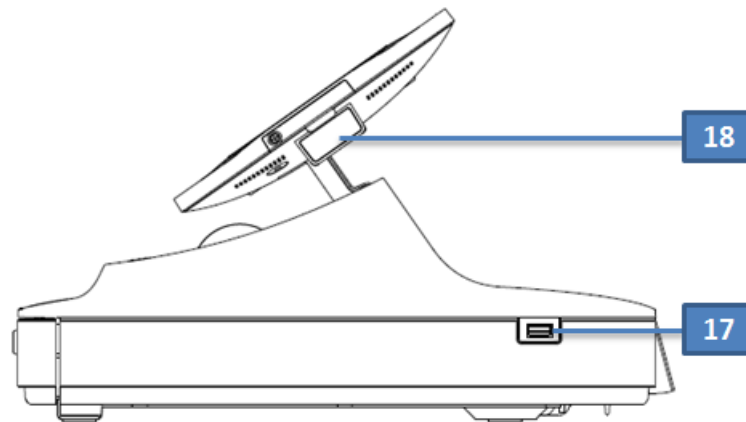

Figure 2. Elo PayPoint iPad® Dock side view (left)

1	Magnetic Swipe Reader (MSR)	10	Tray Mounting Screws
2	Apple® iPad Tray (Apple® iPad 4/ Apple® iPad Air)	11	iPad Eject Button
3	Printer Paper Feed Button	12	Customer Facing Display
4	Cash Drawer	13	Cash drawer manual release latch
5	Check compartment slot	14	Power port
6	Receipt Printer	15	RJ-45 Serial Port
7	Cash drawer lock*	16	Power Button Access
8	Printer head release button	17	USB Charging Port
9	Lightening Connector Cap	18	Barcode Scanner

*\*The Elo PayPoint iPad® Dock comes with a set of two keys for easy locking/unlocking.*

## **A. Register Display Head**

The Elo PayPoint iPad® Dock display head can be flipped to allow customers to complete purchase transactions by self-swiping payment cards, and to authorize transactions by signing directly onto the touchscreen.

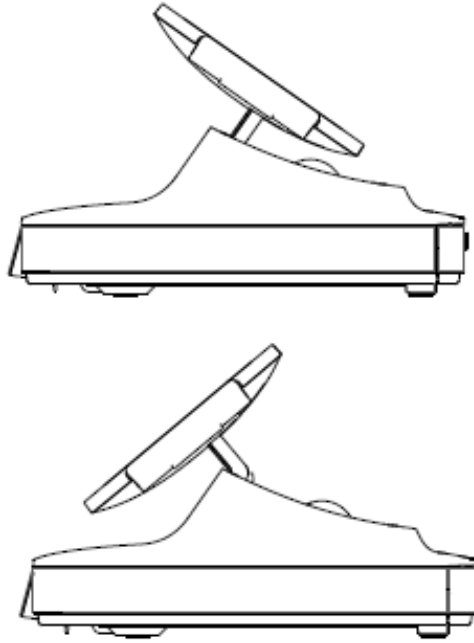

Figure 3. Elo PayPoint iPad® Dock display head can be flipped and supports two configurations: Elo PayPoint iPad® Dock Register clerk-facing view (top) and customer-facing view (bottom)

### **1. Magnetic Stripe Reader (MSR)**

The register has a built in encryptable magnetic stripe reader. Application provider is responsible for correctly encrypting the reader.

When the register is in clerk view, the MSR will be on the left of the register display head. When register is in customer view, the MSR will be on the right of the register display head.

### **2. Apple® iPad Tray**

Elo PayPoint iPad® Dock comes with 3 configurations of trays to support multiple versions of iPads.

### **3. Printer Paper Feed Button**

Elo PayPoint iPad Dock has printer paper feed button to allow user to feed empty receipt paper. One press will feed about 1-inch of thermal paper.

### **4. Cash drawer**

The register is equipped with a cash drawer for storing bills, coins, and checks

## **5. Check compartment slot**

The cash drawer is designed with a slot for slipping checks into the cash drawer.

## **6. Receipt printer (built-in)**

The register is equipped with a built-in receipt printer that is located on the register base.

## **7. Cash drawer lock**

Use the key that comes to lock / unlock the cash register. When cash drawer is locked, cash drawer will not open even when it is commanded to.

## **8. Printer head release button**

Press this release button to release the printer head cover. For more information on how to change printer paper on the register, refer to the “Printer Maintenance” section.

## **9. Lightning™ Connector Cap**

Fasten lightening connector to establish connection between the Dock and iPad.

## **10. Tray Mounting Screws**

Use the tray mounting screws to switch between trays.

## **11. Eject button**

Allows to eject the iPad from dock once the lightening connector cap is open.

## **12. Customer-facing display**

The register base is equipped with a customer-facing display. As store clerks ring up customer orders, the customer facing display will display each order.

## **13. Cash drawer manual release latch**

A latch located on the bottom of the register base can be used to manually open the cash drawer.

## **14. Power Port**

To power the register, plug one end of the power cable to the register power port, and the other end to the wall.

## **15. Serial Port**

Serial port to connect to Elo qualified Serial devices like weigh scale. RJ-45 to DB9 serial cable is included in the packaging.

## **16. iPad Power Button Access**

Will allow user to access iPad power button when the device is docked.

## **17. USB Charging port**

Equipped with a USB charging port to charge your mobile phone or other USB devices

## **18. Barcode scanner**

The register has a built in barcode scanner that scans 1-D barcodes. When the register is in clerk view, the barcode scanner will be on the right of the register display head.

# Docking the iPad

---

## Step 1 :

Identify which mounting tray fits your Apple® iPad. If you have an Apple® iPad Air, system comes with Apple® iPad air tray pre-installed. If you have an Apple® iPad 4 you will need to remove Apple® iPad Air tray and mount Apple® iPad 4 tray.

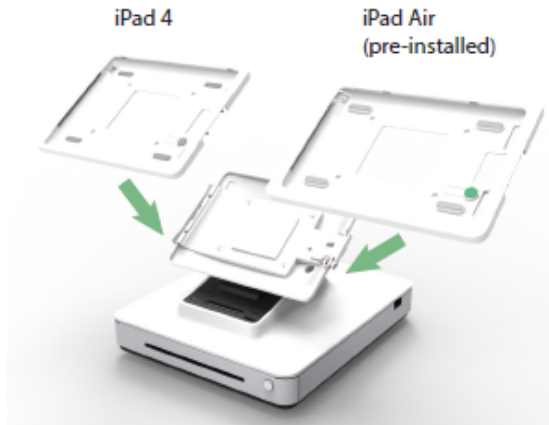

## Step 2 :

Remove 4 mounting screws to swap mounting trays if required.



## Step 3:

Ensure lightning connector is pulled out before installing and iPad version





**Step 4 :**

Install the iPad by inserting top side first and then lightening connector side last.



**Step 5 :**

Press lightening connector cap into the tray and fasten locking screw if desired.



**Step 6 :**

iPad can be removed by pressing eject button on the backside of tray after lightening connector cap is pulled out



# Power

---

The maximum voltage, frequency and current for the register, are provided in the power ratings table below:

	Operating Voltage Range	Operating Frequency Range	Operating Current Range
Elo PayPoint Apple® iPad Dock	100 - 230Vac	50 – 60 Hz	0.1 – 0.3 Aac

# Chapter 3: Technical Support

## Solutions to Common Problems

Problem	Suggested Troubleshooting
The Elo PayPoint iPad® Dock does not respond when turning on the system.	<p>Check that the power cable is properly connected to both the register and the wall. Feed button LED will be white when register is properly connected to the wall.</p> <p>OR</p> <p>Unplug the power cable, re-plug after five seconds</p> <p>OR</p> <p>In the case that the power button LED displays solid white light, which suggests that the system is on, ensure Apple® iPad is properly connected to the lightning connector and indicates Apple® iPad is Charging.</p>
Receipt printer does not print text on the receipt paper	<p>Ensure that the thermal receipt paper is installed in the printer in the proper orientation.</p> <p>Note: Only one side of the thermal paper is coated with the dye that changes color when heated. This is the side that will need to contact the printer thermal head.</p> <p>Refer to printer maintenance chapter on how to properly install the thermal receipt paper in the receipt printer.</p> <p>OR</p> <p>Try unplugging the power code and re-plugging it.</p>
Poor receipt printing quality	Poor receipt printing quality may be due to the use of poor quality thermal paper. Refer to printer

	<p>maintenance chapter for more information on recommended thermal paper for the Apple® iPad dock receipt printer.</p>
<p>Receipt printer does not run when it's supposed to</p>	<p>Push the receipt head release button, lift receipt printer head cover, and check that there is no paper jam. Clear any paper jam.</p>
<p>MSR does not read card properly</p>	<p>The MSR may not function properly when dirty. Use MSR cleaning cards (purchasable in some office supply stores).</p>
<p>Cash drawer doesn't open</p>	<p>Check to ensure that cash drawer lock is not in lock position.</p> <p>OR</p> <p>Use the cash drawer manual release latch to open drawer.</p>

# Chapter 4: Safety & Maintenance

## Safety

---

To avoid risk of electric shock, follow all safety notices and do not disassemble the Elo PayPoint Apple® iPad Dock.

The dock is equipped with a power cable. Do not use a damaged power cable. Use only the power cable supplied by Elo Touch Solutions for the Elo PayPoint Apple® iPad Dock. Use of an unauthorized power cable may invalidate your warranty.

Ensure that the system is maintained and runs within the specified environmental conditions listed below.

### Environmental conditions for operating and storage

Temperature:

Operating	0°C to 35°C
Storage	-30°C to 60°C

Humidity (non-condensing):

Operating	20% to 80%
Storage	5% to 95%

Altitude:

Operating	0 to 3,048 m
Storage	0 to 10,668 m

# Care and Handling

---

The following tips will help maintain optimal performance of your dock:

- Disconnect the power cable before cleaning.
- To clean the unit, use a soft cotton or microfiber cloth lightly dampened with a mild detergent.
- It is important that your unit remains dry. Do not get liquids on or inside the unit. In the event that liquid does get inside, have a qualified service technician inspect the unit before you power it on again.

## Printer Maintenance

---

### Changing Printer Paper

The register receipt printer operates using heat, and not with ink. Printer paper compatible with the Elo PayPoint iPad® Dock receipt printer are as follows:

Type: Thermal Paper (2 ¼ inches x 80 feet)

Paper width: 2 ¼ inches (58 mm)

Paper roll diameter: 1 7/8 inches (50 mm) (maximum)

Paper length: 80 feet (24.4 m)

Printing width: 48 mm

To change the paper for the receipt printer:

1. Ensure that the register display head is flipped away from the receipt printer (in customer-facing view).
2. Push the receipt printer head release button to release the printer head cover.
3. Lift printer head cover.

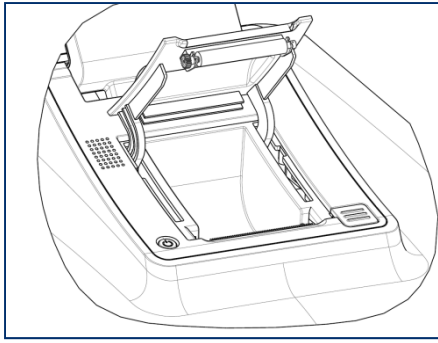

4. Take out the roll of used printer paper, and replace with new roll of printer paper. Make sure that the paper is placed and positions in the correct orientation, as shown below.

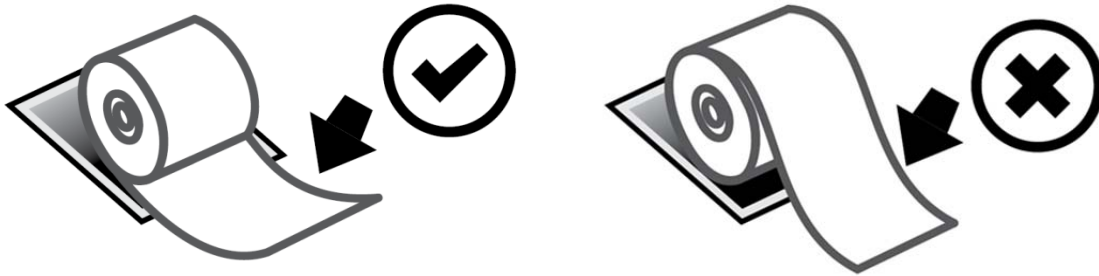

## Cleaning and Care of Printer

The following tips will help maintain optimal performance of your receipt printer:

- Do not pull any paper that is ejected from the printer.
- Do not touch the printer roller or thermal head surface with bare hands. In the case of contact between printer roller or thermal head and hands, clean the roller and/or thermal head surface with alcohol, as specified in the latter parts of this section herein.

Note: Contaminating heating elements with any oil or grease (e.g. oil from hands) may shorten the life of the thermal head.

- Do not print when there is no receipt printer installed in the printer.

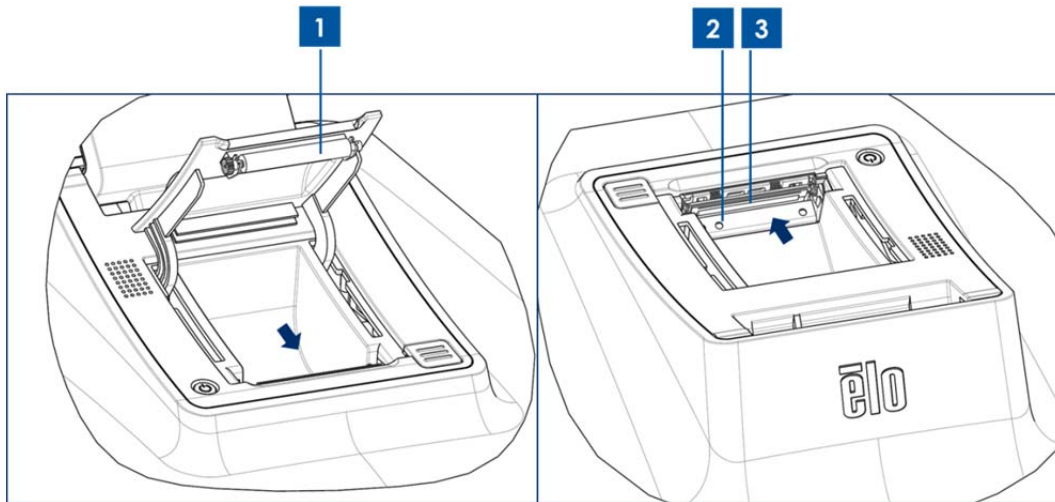

Figure 4. View of receipt printer when printer head cover is open (left). View of the receipt printer according to the view denoted by the arrow.

Prior to cleaning the receipt printer, ensure that the register display head is flipped away from the receipt printer (in customer-facing view). Push the receipt printer head release button to release printer head cover and access the different printer components listed in Figure 4 above. Guidance on how to clean the printer photo-sensor, thermal head, and roller are as follows:

### 1. Photo-sensor:

It is recommendable to clean the printer photo-sensor once a month. To do so:

- a. Use a Nylon brush (or equivalent) to brush off any paper dust or other residues that may be on the photo-sensor.

### 2. Thermal head

It is recommendable to clean the printer thermal head once a month. To do so:

- a. Moist cotton swab with isopropyl alcohol.
- b. Wipe the thermal head with the cotton swab to remove any stain from the thermal head.
- c. Use a dry soft cloth to wipe the thermal head.
- d. Wait to allow the thermal head to dry off, and then shut the printer head cover.

### 3. Roller



It is recommendable to clean the printer roller once a month. To do so:

- a. Apply isopropyl alcohol onto a cloth.
- b. Wipe off any stain from the printer roller with the alcohol dampened cloth.
- c. Use a dry soft cloth to wipe the roller.
- d. Wait to allow the roller to dry off, and then shut the printer head cover.

## Waste Electrical & Electronic Equipment

---



This product should not be disposed of with household waste. It should be deposited at a facility that enables recovery and recycling. Ensure that product is disposed at the end of its useful life according to local laws and regulations.

Elo has put in place recycling arrangements in certain parts of the world. For information on how you can access these arrangements, please visit <http://www.elotouch.com/AboutElo/ewaste-program/>.

# Chapter 5: Regulatory Information

## I. Electrical Safety Information

---

Compliance is required with respect to the voltage, frequency, and current requirements indicated on the manufacturer label. Connection to a different power source than those specified herein will likely result in improper operation, damage to the equipment or pose a fire hazard if the limitations are not followed.

There are no operator serviceable parts inside this equipment (except for replacement of the receipt printer paper). There are hazardous voltages generated by this equipment which constitute a safety hazard. Service should be provided only by a qualified service technician.

Contact a qualified electrician or the manufacturer if there are questions about the installation prior to connecting the equipment to mains power.

## II. Emissions and Immunity Information

---

### Notice to Users in the United States:

This device complies with Part 15 of the FCC Rules. Operation is subject to the following two conditions: (1) This device may not cause harmful interference, and (2) this device must accept any interference received, including interference that may cause undesired operation.

This equipment has been tested and found to comply with the limits for a Class B digital device, pursuant to Part 15 of FCC Rules. These limits are designed to provide reasonable protection against harmful interference in a residential installation. This equipment generates, uses, and can radiate radio frequency energy and, if not installed and used in accordance with the instructions, may cause harmful interference to radio communications. However, there is no guarantee that interference will not occur in a particular installation. If this equipment does cause harmful interference to radio or television reception, which can be determined by turning the equipment off and on, the user is encouraged to try to correct the interference by one or more of the following measures:

- Reorient or relocate the receiving antenna.
- Increase the separation between the equipment and receiver.
- Connect the equipment to an outlet on a circuit different from that to which the receiver is connected.
- Consult the dealer or an experienced radio/TV technician for help.

FCC Caution: Any changes or modifications not expressly approved by the party responsible

for compliance could void the user's authority to operate this equipment.

This transmitter must not be co-located or operating in conjunction with any other antenna or transmitter.

Notice to Users in Canada:

This device complies with RSS-210 of the Industry Canada rules. Operation is subject to the following two conditions: (1) This device may not cause harmful interference, and (2) this device must accept any interference received, including interference that may cause undesired operation.

*Ce dispositif est conforme à la norme CNR-210 d'Industrie Canada applicable aux appareils radio exempts de licence. Son fonctionnement est sujet aux deux conditions suivantes: (1) le dispositif ne doit pas produire de brouillage préjudiciable, et (2) ce dispositif doit accepter tout brouillage reçu, y compris un brouillage susceptible de provoquer un fonctionnement indésirable.*

### III. Radio Frequency Exposure

---

Notice to Users in the United States:

The radiated output power of this device is far below the FCC radio frequency exposure limits. Nevertheless, the device shall be used in such a manner that the potential for human contact during normal operation is minimized.

In order to avoid the possibility of exceeding the FCC radio frequency exposure limits, human proximity to the antenna shall not be less than 20 cm (8 inches) during normal operation.

Notice to Users in Canada

This equipment complies with IC radiation exposure limits set forth for an uncontrolled environment. This equipment should be installed and operated with minimum distance 20 cm between the radiator & your body.

This Class B digital apparatus complies with Canadian ICES-003.

*Cet équipement est conforme aux limites d'exposition aux rayonnements IC établies pour un environnement non contrôlé. Cet équipement doit être installé et utilisé avec un minimum de 20 cm de distance entre la source de rayonnement et votre corps.*

*Cet appareil numérique de la classe B est conforme à la norme NMB-003 du Canada.*

### III. Agency Certifications

---

The following certifications and marks have been issued or declared for the Elo PayPoint Apple® iPad Dock:

- United States FCC
- United States UL

# Chapter 6: Warranty Information

For warranty information, go to <http://www.elotouch.com/Support/warranty.asp>

# Getting in Touch with Us

---

To find out more about Elo PayPoint Apple® iPad Dock, visit our website at [www.elopaypoint.com](http://www.elopaypoint.com), or simply contact us at:

## Elo Touch Solutions

1033 McCarthy Blvd  
Milpitas, CA 95035

**Tel: +1 (844)-PAYPOINT**

**Email: [customerservice@elopaypoint.com](mailto:customerservice@elopaypoint.com)**

To find out more about the extensive range of Elo Touch Solutions products, visit our website at [www.elopaypoint.com](http://www.elopaypoint.com), or simply call the office nearest to you:

### North America

Elo Touch Solutions  
1033 McCarthy Blvd  
Milpitas, CA 95035

Tel 800-ELO-TOUCH

Tel 1-408-597-8000

Fax 1-408-597-8050

[customerservice@elotouch.com](mailto:customerservice@elotouch.com)

### Europe

Tel +32 (0) 16 70 45 00

Fax +32 (0) 16 70 45 49

[elosales@elotouch.com](mailto:elosales@elotouch.com)

### Asia-Pacific

Tel +86 (21) 3329 1385

Fax +86 (21) 3329 1400

[www.elotouch.com.cn](http://www.elotouch.com.cn)

### Latin America

Tel 786-923-0251

Fax 305-931-0124

[www.elotouch.com](http://www.elotouch.com)

## Disclaimer

Nothing herein shall be construed as limiting or reducing your obligations to comply with any applicable laws, regulations or industry standards relating to security or otherwise including, but not limited to, PA-DSS and PCI DSS.

You or the retailer may undertake activities that may affect compliance. For this reason, Elo Touch Solutions is required to be specific to only the standard software provided by it.

Use of Elo PayPoint iPad® Dock products and services is subject to the Elo PayPoint Terms and Conditions of Use which may be found on Elo's website: [www.elopaypoint.com](http://www.elopaypoint.com).

The information in this document is for information purposes only and subject to change without notice. Elo Touch Solutions, Inc. and its affiliates (collectively "Elo") makes no representations or warranties with respect to the contents herein, and specifically disclaims any implied warranties of merchantability or fitness for a particular purpose. Elo reserves the right to revise this publication and to make changes from time to time in the content hereof without obligation of Elo to notify any person of such revisions or changes.

No part of this publication may be reproduced, transmitted, transcribed, stored in a retrieval system, or translated into any language or computer language, in any form or by any means, including, but not limited to, electronic, magnetic, optical, chemical, manual, or otherwise without prior written permission of Elo Touch Solutions, Inc.

Elo, the Elo logo, Elo Touch, Elo Touch Solutions, Elo TouchSystems and Elo PayPoint are trademarks of Elo Touch Solutions, Inc. and its affiliates.

All other product and company names used herein may be trademarks of their registered owners.

## First Edition (August 2014)

Copyright 2013 Elo Touch Solutions, Inc. All rights reserved.